

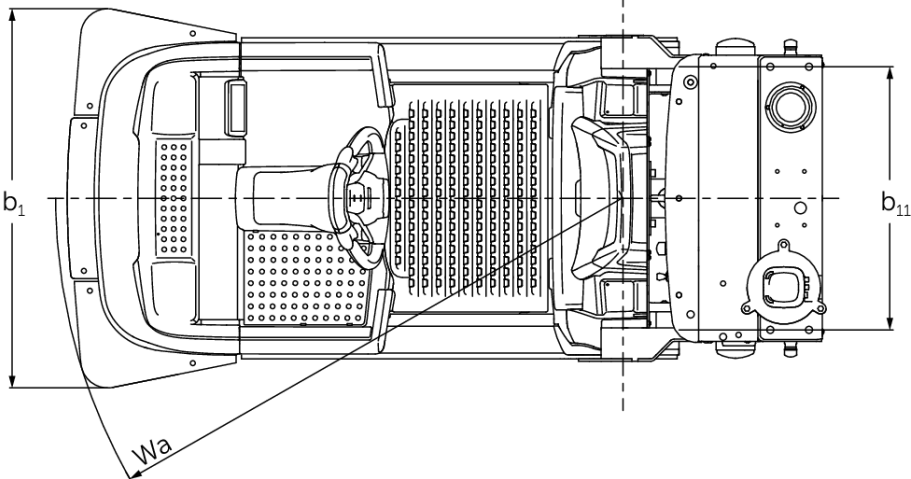

## **EZS 350a**

**Capacity: 5000 kg**

# EZS 350a

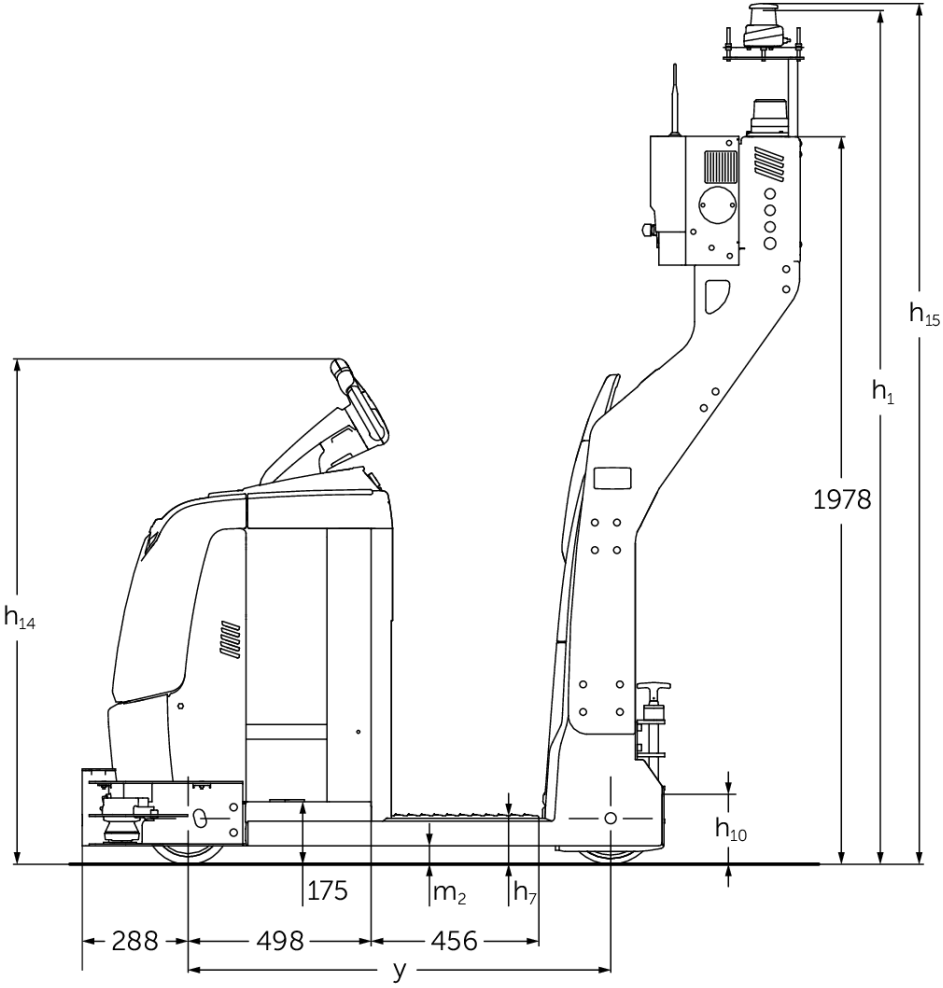

# VDI table

Stand-on: 12/2019

Characteristic	1.1	Manufacturer (abbreviated description)		Jungheinrich	
	1.2	Manufacturer's type designation		<b>EZS 350a</b>	
	1.3	Drive		Electric	
	1.4	Operation		Automatic high-rack stacker	
	1.5	Capacity/load	Q	kg	5.000
	1.9	Wheelbase	y	mm	1.149
Weights	2.1.1	Service weight (incl. battery)		kg	1.333
	2.3	Axle load unladen front/rear		kg	594 / 739
Wheels/suspension system	3.1	Tyres			Vu
	3.2	Tyre size, front			ø230 x 77
	3.3	Tyre size, rear			ø250 x 80
	3.5	Wheels, number front/back (x=driven)			1x/2
	3.7	Tread width, rear	b <sub>11</sub>	mm	680
Basic dimensions	4.2.1	Overall height	h <sub>15</sub>	mm	2.273
	4.19	Overall length	l <sub>1</sub>	mm	1.962
	4.21	Overall width	b <sub>1</sub> /b <sub>2</sub>	mm	980
	4.35	Turning radius	W <sub>a</sub>	mm	1.466
Performance data	5.1	Travel speed laden/unladen		km/h	8 / 12.5
	5.10	Service brake			generative
E-motor/ Electronics	6.1	Drive motor, performance S2 60 min		kW	2.8
	6.4	Battery voltage / nominal capacity		V / Ah	24 / 620
	6.5	Battery weight		kg	460
Miscellaneous	8.1	Type of drive control			AC speedCONTROL
	10.7	Sound level as per EN12053, operator's ear		dB (A)	66

- In accordance with VDI Guideline 2198 this data sheet provides details of the standard truck only. Non-standard tyres, different masts, optional equipment, etc. may result in different values.

- 4.12: other coupling heights available - 4.19: without option S3000, without coupling - 5.1: in manual operation. See diagram - 5.5: Rated drawbar pull

The German production facilities in  
Norderstedt, Moosburg and Landsberg  
are certified.

ISO 9001  
ISO 14001

Jungheinrich fork lift trucks meet  
European safety requirements.



 **JUNGHEINRICH**

The Jungheinrich logo, featuring a red upward-pointing arrow integrated into the letter 'J', followed by the brand name 'JUNGHEINRICH' in a bold, black, sans-serif font.