

Corrosion-resistant

Hygienic and food-neutral
due to smooth surface

Optimum traction
with 2 motors

Jet proof

Electric steering



EJE i25/EJC i15/EJC i15z

Stainless steel pallet trucks (2,500/1,500 kg)

Jungheinrich stainless steel pallet trucks are designed for hardest applications in corrosive and humid environments as well as satisfying the most stringent hygienic requirements. Two separate motors assure powerful drive and excellent handling, even on difficult surfaces. High

quality stainless steel and fully enclosed electronics to protect against jet washing allows easy cleaning and disinfection. Added to this are high-technology seals with moving components offering extra protection. This more than satisfies the high demands made in the food, phar-

maceutical and chemical industries. The stand-on platform (optional) transforms the truck easily from a pedestrian operated into a ride-on truck and thus increases operating comfort, especially during transport over longer distances.

EJE i25/EJC i15/EJC i15z

EJE i25

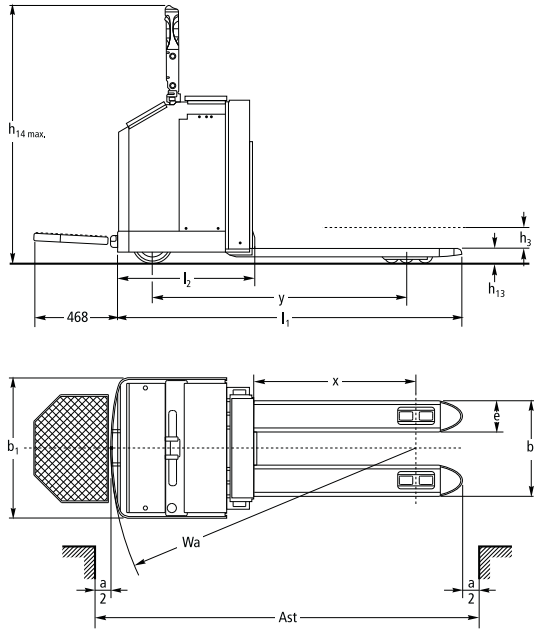

EJC i15z

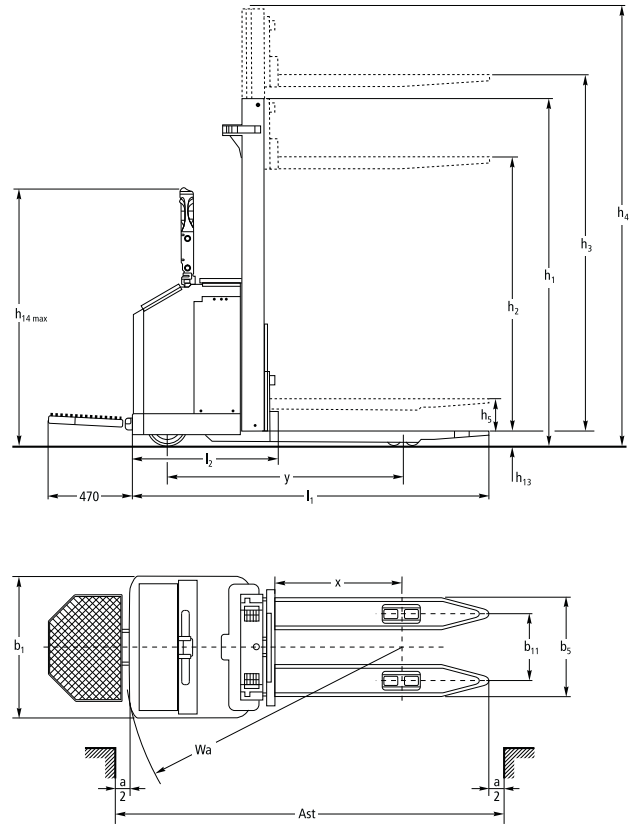

Technical data in line with VDI 2198

			Jungheinrich			
			EJE i25	EJC i15	EJC i15z	
Identification	1.1	Manufacturer (short form)		Jungheinrich		
	1.2	Model				
	1.3	Drive		Electrics		
	1.4	Manual, pedestrian, stand-on, seated, order picker operation		pedestrian		
	1.5	Load capacity/rated load	Q t	2.5	1.5	1.5
	1.6	Load centre distance	c mm		600	
	1.8	Load distance	x mm	1072 ¹⁾	712	709
	1.9	Wheelbase	y mm	1642 ¹⁾	1329	1445
	Weights	2.1.1	Net weight incl. battery (see row 6.5)	kg	862	1212
Wheels / chassis	3.1	Tyres		PU		
	3.2	Tyre size, at front	mm	230 x 75		
	3.3	Tyre size, at rear	mm	85 x 65		
	3.5	Wheels, number front/rear (x = driven wheels)		2-2x/4		
	3.6	Track width, front	b ₁₀ mm		470	
	3.7	Track width, rear	b ₁₁ mm	365	380	380
	Basic dimensions	4.2	Mast height (lowered)	h ₁ mm		2370 ⁵⁾
4.3		Free lift	h ₂ mm		1975 ⁵⁾	1975 ⁵⁾
4.4		Lift	h ₃ mm	120	2000 ⁵⁾	2000 ⁵⁾
4.5		Extended mast height	h ₄ mm		2395 ⁵⁾	2395 ⁵⁾
4.6		Initial lift	h ₅ mm			200
4.9		Height of tiller in drive position min. / max.	h ₁₄ mm		1024 / 1596 ¹⁴⁾	
4.15		Lowered height	h ₁₃ mm		90	
4.19		Overall length	l ₁ mm	1930 ⁹⁾	2016 ¹⁰⁾	2131
4.19.1		total length (long)	mm	2400	2486	2601
4.20		Length incl. back of forks	l ₂ mm	765	816	931
4.21		Total width	b ₁ /b ₂ mm		790	
4.22		Fork dimensions	s/e/l mm	55 / 170 / 1165	75 / 180 / 1200	75 / 190 / 1200
4.25		Width over forks	b ₅ mm	535	560	570
4.32		Floor clearance centre wheelbase	m ₂ mm		40	
4.34		Aisle width for pallets 800 x 1200 lengthways	Ast mm	2198 ¹¹⁾	2253 ⁴⁾¹²⁾	2366 ⁴⁾¹³⁾
4.35	Turning radius	W _a mm	1821 / 2265 ⁸⁾	1561 / 2001 ⁶⁾	1674 / 2115 ⁷⁾	
Performance data	5.1	Travel speed, w. / w.o. load	km/h	5.4 / 6		
	5.2	Lift speed, w. / w.o. load	m/s	0.06 / 0.09	0.16 / 0.25	0.16 / 0.25
	5.3	Lower speed, w. / w.o. load	m/s	0.09 / 0.06	0.38 / 0.12	0.38 / 0.12
	5.8	Max. gradeability, laden/unladen	%	10 / 10		
	5.10	Service brake		electric		
Electrics	6.1	Drive motor rating S2 60 min.	kW	1.5 ²⁾	1.5 ³⁾	1.5 ³⁾
	6.3	Battery according to DIN 43531/35/36 A,B,C, no			no	no
	6.4	Battery voltage/nominal capacity K5	V/Ah		24 / 344	
	6.5	Battery weight	kg		262	
	Misc.	8.1	Type of drive control		AC SpeedControl	

¹⁾ Lowered
²⁾ Two drive motors
³⁾ Two motors
⁴⁾ Values apply for turning in front of empty compartment
⁵⁾ Values for simplex mast: for ZT mast: h₁ 1960 mm h₂ 186 mm h₃ 3000 mm h₄ 3395 mm
⁶⁾ Without platform 1561 mm / with platform opt on 2001 mm
⁷⁾ Without platform 1674 mm / with platform option 2115 mm
⁸⁾ Without platform 1821 mm / with platform opt on (folded out) 2265 mm
⁹⁾ Without platform 1930 mm / with platform option (folded out) 2400 mm
¹⁰⁾ Without platform 2016 mm / with platform option 2486 mm
¹¹⁾ Without platform 2198 mm / with platform option (folded out) 2640 mm
¹²⁾ Without platform 2253 mm / with platform option 3693 mm
¹³⁾ Without platform 2366 mm / with platform option 2807 mm
¹⁴⁾ With platform option: 1024 / 1446 mm

Benefit from the advantages



Easy service access to drive compartment



Enclosed tiller

Two motors – one power package

Optimum operation on virtually all surfaces thanks to robust technology:

- Excellent traction and lateral stability at any time due to two separate drive motors.
- High drive power and reliable braking.
- Production residues and wet floors are not an issue.

Water-resistant

- Withstands high-pressure cleaning and disinfecting:
- Fully sealed tiller arm.
- Waterproof cover for controls and drive.
- Liquids cannot accumulate on the underside of truck.

Hygienic and practical

- Abrasion-proof surface, even with intensive use.
- Resistant to ingress of dirt and bacteria due to glass bead blasting.
- Conforms to EU hygiene directive for foodstuff production.
- Initial lift function (optional) allows for effortless manoeuvring over uneven floors.

High quality materials

The truck is designed to cope easily with its application ensuring high operational availability and long service life:

- Rust-resistant even in corrosive environments.

- The entire chassis consists of robust V2A stainless steel and the mast of extra strong duplex steel.
- All controls are made of high quality plastic.
- Robust 8 mm chassis.

Ergonomic operation

Excellent handling from electronic steering:

- 60° steering lock for 92° cornering.
- Stand-on platform (optional) for longer distances.
- Effortless battery change due to side-ways battery removal.

良友貨架叉車有限公司
香港九龍荔枝角長沙灣道883號
億利工業中心11樓1103室

Mechanical And Transportation Equipment Ltd.
Unit 1103, 11/F Elite Industrial Centre,
883 Cheung Sha Wan Road, Lai Chi Kok
Kowloon, Hong Kong.

Tel : (852) 2744 3535
Fax : (852) 2744 3773
Email : info@matehk.com.hk
Website : <https://www.matehk.com.hk>

The German production facilities in Norderstedt and Moosburg are certified. **ISO 9001**
ISO 14001

Jungheinrich fork lift trucks meet European safety requirements.



JUNGHEINRICH
Machines. Ideas. Solutions.